

# KTZ54X41SANXX Specification

## 1. Executive Standards and Basic Requirements

### 1.1 Executive standards

GB/T18488.1-2015 "Drive motor system for electric vehicles Part 1: Technical conditions"

GB/T18488.2-2015 "Drive motor system for electric vehicles Part 2: Test methods"

GB/T 18384.2-2015 "Safety requirements for electric vehicles Part 2: Operational safety and fault protection"

GB/T 18384.3-2015 "Safety requirements for electric vehicles Part 3: Protection against electric shock to persons"

GB/T 18387-2008 "Limits and measurement methods for electromagnetic field emission intensity of electric vehicles, wideband, 9 kHz to 30 MHz"

GB 14023-2011 Vehicle, Ship, and Internal Combustion Engine Radio Disturbance Characteristics Limits and Measurement Methods Used to Protect Exterior Receivers

GB/T 17619-1998 "Electromagnetic Radiated Immunity Limits and Measurement Methods for Electrical and Electronic Components of Motor Vehicles"

GB/T 2423.17-2008 "Environmental testing of electric and electronic products Part 2 Test methods Test Ka: Salt spray"

### 1.2 Basic Requirements

- 1) The controller shall operate at peak current for 60s, when the cooling water temperature is 60°C and controller is already at heat stable state with rated load.
- 2) The controller shall operate normally when the relatively humidity is lower than 100%, means the controller shall work safely even has condensation on the cover.
- 3) Resistance to salt fog, and shall meet relevant regulations in GB/T 2423.17-2008.
- 4) According to the installation location of the motor controller, the controller shall be able to withstand the sweeping vibration test and random vibration test in up and down, left and right, front and back directions, and meet the requirements of 5.6.4 in GB/T 18488.1-2015;
- 5) The controller housing shall be able to withstand 100Kg of gravity over an area of 30cm x 30cm without significant plastic deformation;
- 6) The dielectric strength between the live circuit of the controller to the earth (enclosure) and the circuit

that is not electrically connected to each other shall be able to withstand the tolerances of 5.2.8.2.3 in GB/T 18488.1-2015 and 7.3 in GB/T 18384.3 2015. The test voltage specified in .3.3.2 has a duration of 1 min;

7) The controller shall be able to safely withstand the maximum current at 120% of the rated supply voltage;

8) The noise emitted by the controller during normal operating conditions shall comply with the noise limits of GB 10069.3-2008;

9) Motor controller shall have short circuit, over current, over voltage, and under voltage protection

10) The clearances and creepage distances between the live circuits of the controller and the live parts and conductive parts or grounding parts shall comply with the national standard; the insulation between the live circuit of the controller and the ground (housing) The resistance is not less than 1 MΩ when the ambient temperature is 40°C and the relative humidity is 95%;

11) The controller shall have good insulation performance. In normal operation, the thermal contact current should not exceed 5mA;

12) The electromagnetic radiation generated by the controller during operation shall not exceed the radiated interference allowable value specified in Chapter 4 of GB/T 18387-2008.

## 2. Detailed Technical Information

1 ) Control board software version and name ( VER : / , NA : / )

2 ) CAN communication board version and name: Meet the format and content of the communication protocol provided by Party A.

### 2.1 Controller Specifications and Functions

#### 2.1.1 Controller Specifications

	Item	Detailed Specification	Note
<b>Rated Parameters</b>	Model	KTZ54X41SANXX	XX indicates that the name is different due to different motor, and CAN protocols. Expressed in digits and letters.
	Applicable motor	PMSM/Three-phase Induction Motor	
	Rated voltage	540V	Input DC voltage
	Rated power	132kW	
	Peak power	198 kW	
	Rated output current	273 A	rms
	Peak output current	410 A	rms , 60s
	Rated Efficiency	≥98%	
<b>Electrical characteristics</b>	Input voltage range	Undervoltage ~ Overvoltage	According to users
	Output frequency	0.00 Hz ~ 600 Hz	
	Switch frequency	Range : 0 kHz~10 kHz Default : 6 kHz	Recommend <6 kHz
	DC bus capacity	470 μF±10%	
	Cy	DC+~housing : 0.33 μF DC-~housing : 0.33 μF	
	Dielectric strength	The controller can withstand 3000V DC between +, -, U, V, W and the housing for a duration of 2S and leakage current <10mA	
	Insulation resistance	Between +, -, U, V, W and housing at steady state>20MΩ	Test conditions: Store at (85 ± 2) °C for 8 hours and take out immediately while measuring the insulation resistance
	Ground continuity	The resistance between the conductive part of	

		controller which user may touch and the housing ground < 0.1Ω	
<b>Mechanical parameters</b>	Weight	9.8±0.5 kg	
	Size	L : 397.5mm , W : 279mm , H : 129.8mm	Including connector
	Power Terminal Bolt Tightening Torque (M8)	Typical value: 25Nm	
	Cover bolt tightening torque (M5)	Typical value: 2.8Nm	
	Power cable waterproof joint tightening torque (recommended)	10Nm	
	Body installation bolt tightening torque	M8 bolt: 25Nm	Thread length >15mm
	Grounding bolt tightening torque (M8)	Typical value: 25Nm	
<b>Water cooling</b>	Rated flow	16L/min	
	Cooling pressure drop T <sub>coolant</sub> =25°C	@ 10L/min : 100 mbar @ 20L/min : 300 mbar	
	Running water pressure	2 bar	
	Seal test	0.35 Mpa for 20min without leakage	
<b>Control voltage</b>	Control voltage range	9V~36V	
	Standby current (IGN ON+ X1:02 lower than threshold voltage or inactive when not connected)	0.5mA	
	Low-voltage power supply current consumption when the controller is operating	+12V power supply, typical value: 2.9A, maximum value: 3.9A +24V power supply, typical value: 1.5A, maximum value: 2.0A	

	normally		
<b>Protection point</b>	IGBT over temp point	105 °C	
	DC over voltage point	Software : 750 V Hardware : 800 V	
	Control voltage lower limit	8 V	
		18 V	
Over current	Software : 420 Arms Hardware : 802 Apeak		
<b>Current and voltage detection</b>	AC current detection range	-819A ~ +819A	
	AC current detection gradient	2.500 digits/A	
	AC current detection bias	2048 digits	
	AC current detection bandwidth (-3dB)	30 kHz	
	DC bus voltage detection range	0~ 1227.3V	
	DC bus voltage detection gradient	3.337 digits/V	
	DC bus voltage detection bandwidth (-3dB)	20 kHz	
<b>Environment</b>	Storage	-40°C ~ +85°C	
	Operation temperature	-40°C ~ +105°C	Derating when the ambient temperature is higher than 85°C
	Relative humidity	5% ~ 95%	No condensation allowed inside the housing
	Coolant temperature	-40°C ~ +75°C	Derating when coolant temperature is higher than 65°C
	Protection level	IP67	
	Altitude	0~2000m	Above 2000m please contact the manufacturer to confirm

<b>Vibration</b>	Sweep vibration	Meet the requirements of 5.6.4.1 of GB/T18488.1-2015	
	Random vibration	Meet the requirements of 5.6.4.2 and GB/T 28046.3-2011 in GB/T18488.1-2015	
<b>Discharge</b>	Active discharge	Down to safety voltage ( 60VDC ) in 3s	
	Passive discharge	Down to safety voltage ( 60VDC ) in 200s	
<b>Sensor</b>	Resolver excitation voltage	AC 6.2~7.5V	rms
	Resolver excitation frequency	10 kHz	
	Motor temperature sensor	NTC KTY81 PT1000 PT100	
<b>Communication</b>	A channel CAN communication	Meet the ISO11898-2 standard; When CANA_TERM (X1:26) is shorted with CANA_L (X1:15), the A channel CAN communication line will be connected with a 120Ω termination resistor; Termination resistor jumper is selected by the user; Factory default: do not connect termination resistors;	Meet the format and content of the communication protocol provided by Party A
	B channel CAN communication	Meet the ISO11898-2 standard; When the CANB_TERM (X1:28) and CANB_L (X1:17) are shorted, the B-channel CAN communication line will be connected to the 120Ω termination resistor; Termination resistor jumper is selected by the user; Factory default: do not connect termination resistors;	Meet the format and content of the communication protocol provided by Party A
<b>Operating Control performances</b>	Speed control range	1:1000	Vector control with sensor
	Speed control accuracy	±0.02%	
	Starting torque	0 Hz, 200%	
	Torque response time	<5 ms	
	Torque control accuracy	±5%	
	Speed limit	Peak speed, Over-speed protection point: rmp	According to motor

	Torque limit	Peak torque: Nm	According to motor
--	--------------	-----------------	--------------------

### 2.1.2 Basic protection function

	Item	Note
<b>Protection function</b>	Interphase short-circuit protection	After the controller enters into the protection state, the fault status shall be transmitted to the vehicle controller according to the communication protocol.
	Earth short-circuit protection	
	Overcurrent protection	
	Overload protection	
	Output phase loss protection	
	Overvoltage protection	
	Undervoltage protection	
	Stall protection	
	Overheating protection	
	Low temperature protection	
	Temperature sensor disconnection protection	
Encoder line breakage protection		
<b>Insulation detection</b>	End-to-ground insulation monitoring at main power side.	It can detect the insulation failure of the DC bus and the three-phase motor line to the ground. After the pre-charge is completed and the operation enable command is given, the detection starts.

## 2.2 Connector

### 2.2.1 Control signal interface

Pin	Name	type	Description	Specification
X1:01	PWR+	Input	Auxiliary Power / Battery "+"	Auxiliary battery positive input ; Voltage range : 9V~16V ;
X1:02	IGN ON+	Input	Controller enable signal	Input voltage : 0V~PWR+ ; Threshold voltage : 6.2V±5% ; Input impedance : ≥ 20kΩ ; Reference ground : PWR- ( X1:05/ X1:13 ) ;
X1:03	HVIL_IN1	Input	High pressure interlock ring	/
X1:04	HVIL_IN2	Input	High pressure interlock ring	/
X1:05	PWR-	Input	Auxiliary Power Ground / Battery "-"	Auxiliary batter negative input

Pin	Name	type	Description	Specification
X1:06	VCC_USER	Output	User power	Voltage : +5V±5% ; Output current :0mA ~50mA ; Reference ground : PWR- ( X1:05/ X1:13 ) ;
X1:07	REF+	Output	Resolver REF+ (complementary output REF-:X1:19)	/
X1:08	SIN-	Input	Resolver SIN- (complementary input SIN+ : X1:20)	/
X1:09	COS-	Input	Resolver COS- (complementary input COS+ : X1:21)	/
X1:10	R2+	Input	Temperature sensor input channel 2+ ( Complementary input R2- : X1:22 )	: NTC KTY81 PT1000 PT100
X1:11	AI1_P	Input	Multifunction analog differential input channel 1+ ( Complementary input 1- : X1:12 )	Voltage range : 0V~ +10V ; Input impedance : 18.5kΩ ;
X1:12	AI1_N	Input	Multifunction analog differential input channel 1- ( Complementary input 1+ : X1:11 )	
X1:13	PWR-	Input	Auxiliary Power Ground / Battery "-"	Auxiliary batter negative input
X1:14	CANA_H	In/Output	A channel CAN+	Comply with ISO11898-2 standard; The terminal resistance selection reference X1:26
X1:15	CANA_L	In/Output	A channel CAN-	Comply with ISO11898-2 standard; The terminal resistance selection reference X1:26
X1:16	CANB_H	In/Output	B channel CAN+	Comply with ISO11898-2 standard; The terminal resistance selection reference X1:28
X1:17	CANB_L	In/Output	B channel CAN-	Comply with ISO11898-2 standard; The terminal resistance selection reference X1:28
X1:18	DO1	Output	Multifunction digital output channel 1	Voltage range : 0V ~PWR+ ; Reference ground : PWR- ( X1:13/ X1:05 ) ; Current range : 0A~1.0A ;



Pin	Name	type	Description	Specification
				With overcurrent function ;
X1:19	REF-	Output	Resolver REF- ( complementary output REF+ : X1:07 )	/
X1:20	SIN+	Input	Resolver SIN+ ( complementary input SIN- : X1:08 )	/
X1:21	COS+	Input	Resolver COS+ ( complementary input COS- : X1:09 )	/
X1:22	R2-	Input	Temperature sensor input channel 2- ( complementary input R2+ : X1:10 )	NTC KTY81 PT1000 PT100
X1:23	R1+	Input	Temperature sensor input channel 1+ ( complementary input R1- : X1:24 )	NTC KTY81 PT1000 PT100
X1:24	R1-	Input	Temperature sensor input channel 1- ( complementary input R1+ : X1:23 )	NTC KTY81 PT1000 PT100
X1:25	DI3	Input	Isolated Multifunction Digital Input 3	Voltage range : 0V ~ PWR+ ; Frequency range: 0Hz~200Hz Input impedance: 2.2k $\Omega$ ;
X1:26	CANA_TERM	Input	A channel CAN communication terminal resistance jumper	When shorted connect CANA_TERM (X1:26) and CANA_L (X1:15) , 120 $\Omega$ terminal resistance will be connected into A channel.
X1:27	DI4	Input	Isolated Multifunction Digital Input 4	Voltage range : 0V ~ PWR+ ; Frequency range: 0Hz~200Hz Input impedance: 2.2k $\Omega$
X1:28	CANB_TERM	Input	B channel CAN communication terminal resistance jumper	When shorted connect CANA_TERM (X1:28) and CANA_L (X1:17) , 120 $\Omega$ terminal resistance will be connected into A channel.
X1:29	AI2_P	Input	Multifunction analog differential input channel 2+ ( complementary input 2- : X1:30 )	Voltage range : 0V~ +10V ; Input impedance : 18.5k $\Omega$ ;
X1:30	AI1_N	Input	Multifunction analog differential input channel 2- ( complementary input 2+ : X1:29 )	
X1:31	DI1	Input	Multifunction analog differential input channel 1	Voltage range : 0V ~ PWR+ ; Frequency range: 0Hz~200Hz

Pin	Name	type	Description	Specification
				Input impedance: 2.2kΩ ;
X1:32	DI2	Input	Multifunction analog differential input channel 2	Voltage range : 0V ~ PWR+ ; Frequency range: 0Hz~200Hz Input impedance: 2.2kΩ ;
X1:33	DI_COM	Signal ground	Signal ground	Isolated Multifunction Digital Input Channel DIx Common Reference Ground
X1:34	DO2	Output	Multifunction analog differential output channel 2	Voltage range : 0V ~PWR+ ; Reference ground : PWR- ( X1:13/ X1:05 ) ; Current range : 0A~1.0A ; With overcurrent protection ;
X1:35	ENCLOSURE	In/Output	Connect to the housing from the controller inside	Connect CAN+/CAN- , E+/E- , SIN+/SIN- , COS+/COS- and other signals shielding with terminals or enclosure

Note : Motor controller side signal interface/ terminal model : 776163-1 , Manufacturer : TYCO ;  
Connector model : 776164-1 , Manufacturer : TYCO;  
Terminal pin model : 770854-3 , Manufacturer : TYCO.

### 2.2.2 Main power terminal

Terminal	Description	Cable diameter Ø Cu /mm <sup>2</sup>	Rated voltage	Rated current
+	High DC voltage "+"	50	900V DC	300A rms
-	High DC voltage "-"	50	900V DC	300A rms
U	Motor U phase	50	900V DC	300A rms
V	Motor V phase	50	900V DC	300A rms
W	Motor W phase	50	900V DC	300A rms

Note : 1、 Waterproof connector of power interface/terminal model: PG21-20MM.

2、 The PE terminal of motor control is connected to the chassis of vehicle with a cable that is not less than the half of cross-sectional area of the power cable (25mm<sup>2</sup>) and the length is as short as possible.

### 2.2.3 Water cooling connector

Terminal	Description
IN	Input
OUT	Output

## 2.3 Controller wiring diagram

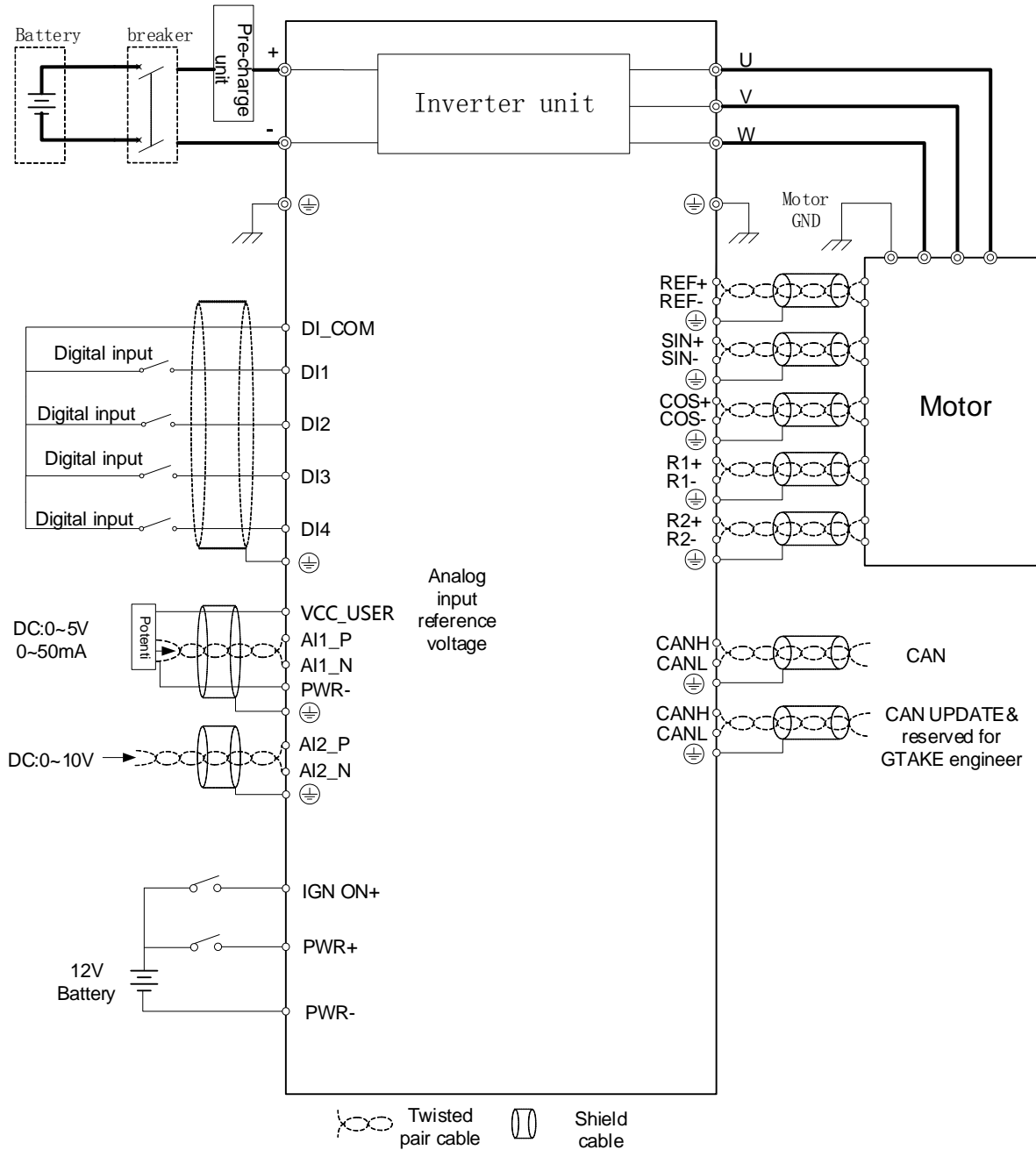

### Note :

1) The motor three-phase cable must be connected to the motor controller and motor housing through shielded connection device, and the two ends should be grounded, otherwise it may cause serious electromagnetic interference;

2) Pins 1 and 13 are +12V/+24V power supply and return line, 1.5A@24V, 2.9A@12V;

3) Pin 2 is the controller enable signal, active high, the threshold voltage:  $6.2V \pm 5\%$ , if it does not need to enable the function, then short-circuit directly with pin 1;

4) Pins 14/15 are A-channel CAN communication high-speed signal wires. Shielded twisted pair differential cable is used. Users can connect internal  $120\Omega$  via short pins 15 and 26.

Terminal resistance access, the factory default does not connect the termination resistor;

5) Pins 10/22, 23/24 are temperature-resistance signal lines. It is recommended to use shielded twisted pair or unshielded cable.

6) Pins 7/19, 8/20, 9/21 are three pairs of resolver signal lines, shielded twisted pair differential cable should be used;

7) The shielding of each shielded cable can be put together, including CAN, R1, R2, REF, SIN and COS, connected to pin X1: 35.

## **2.4 Nameplate**

According to customers' requirements

## 2.5 Structure and installation

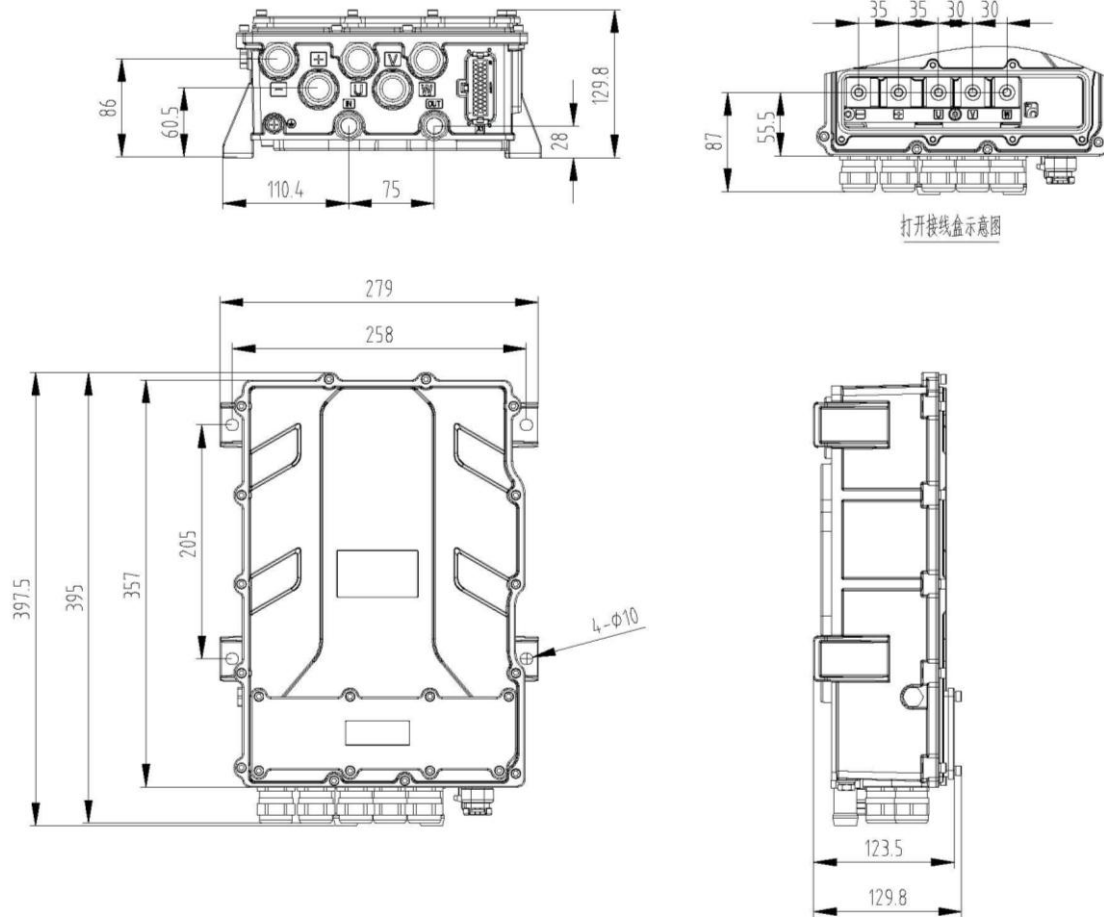

### 3. External View

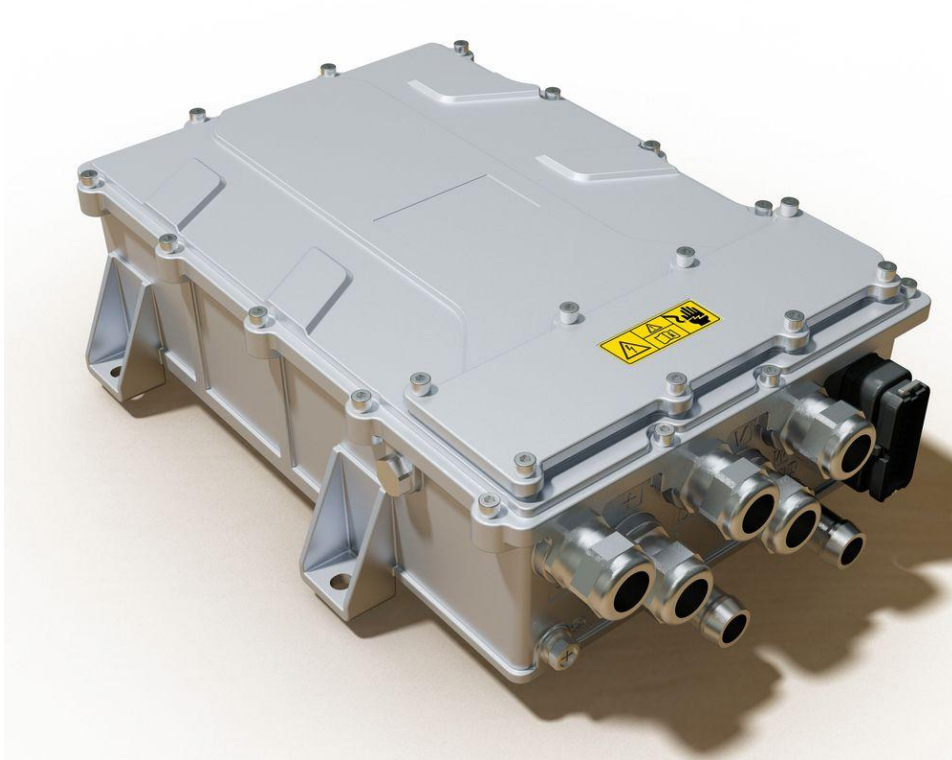

### 4. Warranty

GTAKE shall provide, free of cost, the failed part which under normal and proper use and maintenance within 36 months calculated from the date of shipment of the equipment, or 150,000-kilometer drive, whichever is earlier.